	Akku Tronics New Energy Technology Co., Limited TEL:0086-755-85290393 FAX:0086-755-86578846	Type: ICR18650-3S9P
		REV: 1.0
		Date: 2020-03-03

Specification Approval Sheet

Model : ICR18650-3S9P
Type : Li-ion battery pack
Specification : 11.1V/30.15Ah

signed by client	
Confirmed	
Checked	
Approved	

signed by manufacturer	
Prepared:	Alex Wang
Checked:	Howell Zhu
Approved:	Xueming Zhao

	Akku Tronics New Energy Technology Co., Limited TEL:0086-755-85290393 FAX:0086-755-86578846	Type: ICR18650-3S9P
		REV: 1.0
		Date: 2020-03-03

Revision Records

REV	ISSUE	CONTENT OF AMENDMENT	PRE.	CHE.	APP.
1.0	Mar 3, 2020	New release	Alex Wang	Howell Zhu	Xueming Zhao
END					

	Akku Tronics New Energy Technology Co., Limited TEL:0086-755-85290393 FAX:0086-755-86578846	Type: ICR18650-3S9P
		REV: 1.0
		Date: 2020-03-03

Content

1. Battery type and scope -----	3
2. Basic characteristic of the battery-----	3
2.1: Basic performance parameter of the battery -----	3
2.2: Basic performance parameter of the cell -----	4
2.3: Electrical performance test of cell -----	5
2.4: Safety performance test of cell-----	6
3. Dimension and Description-----	7
Attentions -----	8-9

	Akku Tronics New Energy Technology Co., Limited TEL:0086-755-85290393 FAX:0086-755-86578846	Type: ICR18650-3S9P
		REV: 1.0
		Date: 2020-03-03

1. Battery type and scope

This Specification Approval Sheet is for rechargeable Li-ion battery pack provided by Akku Tronics New Energy Tech. Co., Ltd.

2. Basic characteristic of the battery

2.1 Basic performance parameter of the Battery

S/N	Details	Parameters		Remarks
1	Rated voltage	11.1V		
2	Rated capacity	30.15Ah		Std. charge / discharge at room temperature (24±2°C)
	Minimum capacity	29.25Ah		
3	Charge	Limited voltage	12.6V	0.3C
		Standard current	8.75A	
4	Discharge	Limited voltage	7.5V	0.2C
		Standard current	5.85A	
5	Max. dimension	L: 105.5max; W: 96.5 max; H 73max		unit: mm
6	Weight	1.4kgs max.		approx..

2.2 Basic performance parameter of the cell

S/N	Details	Parameters		Remarks
1	Rated voltage	3.7V		
2	Rated capacity	3350 mAh		Std. charge / discharge at room temperature (24±2°C)
	Minimum capacity	3250 mAh		
3	Charge	Limited voltage	4.2±0.05V	4.2V till 50mA 0.3C (24±2°C)
		Mode	C.C/C.V.	
		Standard current	975mA	
4	Discharge	Limited voltage	2.5V	0.2C (24±2°C)
		Standard current	650mA	

Add.: Rm 529, Huichao Bldg, Yintian Industrial Area, 4008 Bao'an Rd, Shenzhen, China.
 Website: <http://www.akkutronics.com>

	Akku Tronics New Energy Technology Co., Limited TEL:0086-755-85290393 FAX:0086-755-86578846	Type: ICR18650-3S9P
		REV: 1.0
		Date: 2020-03-03

		Max. Discharge Current	0.5C(1625mA)	-20 ~ 5°C
			1.5C(4875mA)	5 ~ 45°C
			1.5C(4875mA)	45 ~ 50°C
5	Working temperature	Charging	0~45°C	(cell skin temperature ~60°C)
		Discharging	-20~50°C	
6	Storage temperature	1 month	-20 ~ 50°C	Charge to 40%~50% of full capacity when storage
		6 months	-20 ~ 45°C	
		1 year	-20 ~ 20°C	
7	Storage humidity	45% ~ 75%	Relative humidity	
8	Inner resistance	≤ 70 mΩ		
9	Weight	Max. 49.0 g		
10	Max. dimension	Max φ 18.4 mm; H: ≤ 65.15 mm		
11	Cycle life	300 times		≥ 75% Cini (initial capacity)

2.3 Electrical performance test of cell

S/N	Inspection item	Standard	Testing Method
1	Initial Capacity	≥3250 mAh	Cells shall be charged per 2.2.3 and discharged per 2.2.4 within 1h after full charge.
2	High/Low temperature discharge capacity	-10° C: ≥70% of Cini 0° C: ≥80% of Cini 24° C: ≥100% of Cini 50° C: ≥95% of Cini	Cells shall be charged per 2.2.3 and discharged per 2.2.4 at the following temperatures: -10° C, 0° C, 24° C and 50° C.
3	Cycle life	≥75% of Cini	Cells shall be charged per 2.2.3 and discharged per 2.2.4 for 300 cycles. A cycle is defined as one charge and one discharge. The 301st discharge capacity shall be measured.

	Akku Tronics New Energy Technology Co., Limited TEL:0086-755-85290393 FAX:0086-755-86578846	Type: ICR18650-3S9P
		REV: 1.0
		Date: 2020-03-03

4	Capacity Retention	Capacity remaining rate $\geq 90\%$	Cells shall be charged per 2.2.3 and stored in a temperature-controlled environment at $24^{\circ}\text{C} \pm 2^{\circ}\text{C}$ for 30 days. After storage, cells shall be discharged per 2.2.4 to measure the remaining capacity.
---	--------------------	-------------------------------------	--

2.4 Safety performance test of cell

1	High Temperature and High Humidity Test	No leakage, No rust Capacity recovery $\geq 80\%$ (Cmin)	Cells are charged per 2.2.3 and stored at 60°C (95% RH) for 168 hours. After test, cells are discharged per 2.2.4 for 3 cycles to measure recovered capacity.
2	Vibration	No leakage	Cells charged per 2.2.3 are vibrated for 90 minutes per each of the three mutually perpendicular axis (x, y, z) with total excursion of 0.8mm, frequency of 10Hz to 55Hz and sweep of 1Hz change per minute
3	Impact	No explosion, No fire	Cells charged per 2.2.3 are impacted with their longitudinal axis parallel to the flat surface and perpendicular to the longitudinal axis of the 15.8mm diameter bar (Per UL1642).
4	Free Drop	No leakage No temperature rising	Cells charged per 2.2.3 are dropped onto a wooden floor from 1 meter height for 1 cycle, 2 drops from each cell terminal and 1 drop from the side of cell can (Total number of drops = 3).
5	External Short circuit	No explosion, No fire	Cells are charged per 2.2.3, and the positive and negative terminal is connected by a $100\text{m}\Omega$ -wire for 1 hour (Per UL1642).
6	Overcharge	No explosion, No fire	Cells are discharged per 2.2.4, then charged at constant current of 3 times the max. charge condition and constant voltage of 4.2V while tapering the charge current. Charging is continued for 7 hours (Per UL1642).
7	Crush	No explosion, No fire	Cells charged per 2.2.3 are crushed with their longitudinal axis parallel to the flat surface of the crushing apparatus (Per UL1642).
8	Thermal Shock	No leakage Capacity recovery rate $\geq 80\%$ (Cmin)	65°C (8h) \leftarrow 3hrs \rightarrow -20°C (8h) for 8 cycles with cells charged per 2.2.3 After test, cells are discharged per 2.2.4 and cycled for 3 cycles to measure recovered capacity.

	Akku Tronics New Energy Technology Co., Limited TEL:0086-755-85290393 FAX:0086-755-86578846	Type: ICR18650-3S9P
		REV: 1.0
		Date: 2020-03-03

9	Overdischarge	No explosion, No fire	Cells are discharged at constant current of 0.2C to 250% of the minimum capacity.
10	Heating	No explosion, No fire	Cells are charged per 2.2.3 and heated in a circulating air oven at a rate of 5°C per minute to 130°C. At 130°C, oven is to remain for 10 minutes before test is discontinued (Per UL1642).

3. Dimension and Description

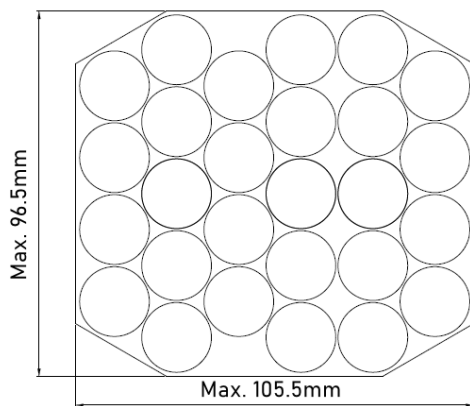

Description:

1. Cell: 18650 3350mAh, 3pcs in series, 9pcs in parallel
2. Wire: Black 60mm
3. Connector: Right angle DC power plug 2.5x5.5mm, MCM 27-5903
4. Shrink black PVC

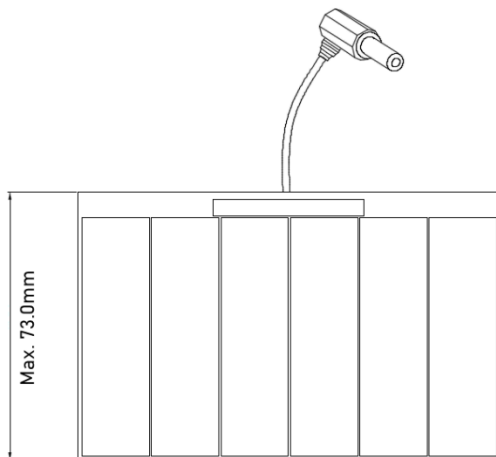

	Akku Tronics New Energy Technology Co., Limited TEL:0086-755-85290393 FAX:0086-755-86578846	Type: ICR18650-3S9P
		REV: 1.0
		Date: 2020-03-03

Attentions

Danger

To prevent battery from weeping, fever, exploding, please obeys the rules as follows:

Do not immerse the battery into the water or the sea, Guard against Damp;

Do not approach the heat source, like fire or heater;

Please use the appointed charger when charging;

Do not transposition the +.- poles of the battery to charge;

Do not direct-connected the battery to alternating current power supply, or auto-ignition of the vehicle;

Do not discard the battery to the fire or hyperpyretic objects;

Do not use the conductor to lead the short circuit of the + -poles of the battery. Do not put the battery with metallic conductors to transport or store, like necklace, hairpin and so on;

Do not beat or throw the battery;

Do not impale the battery with needle or some other sharp things, do not strike it with weight;

As installed safety device in the battery, please do not resolve or change any other sections of the battery to protect the inherent safety functions.

Warnings

Do not put the battery to the microwave oven or pressure tank;

Do not use the battery with some chemical batteries (like dry battery) or different capacities and brands battery together, if the battery emits the smell, heat , changes color, be out of shape or appears any other abnormal phenomena during the charging or stored procedures, please get out the battery from the device or charger and stop using;

If cannot recharge within the charging period, please not continue charging;

Put the battery to where the kids can not touch, if the kids swallow the battery, please seeing the doctor soon;

If the electrolyte of the battery into the eyes, do not rub, should wash the eyes first, then see the doctor.

Announcements

Do not put the battery under the high temperature places (like sunshine irradiation or car in the hot weather), or it will catch fire for the heat, reduce the performance and loss the life;

To ensure the safety, the battery should install the safety device, please not use when the static electricity is more than we need when produce, or the safety device will lose efficacy and lead the overheating, fracture, exploding and catching fire.

Safety charger voltage: $4.2 \pm 0.05V$

Protection device (FYI): Over charge detection voltage $4.25 \pm 0.02V$

Over discharge detection voltage: $3.00 \pm 0.10V$

Add.: Rm 529, Huichao Bldg, Yintian Industrial Area, 4008 Bao'an Rd, Shenzhen, China.

Website: <http://www.akkutronics.com>

	Akku Tronics New Energy Technology Co., Limited TEL:0086-755-85290393 FAX:0086-755-86578846	Type: ICR18650-3S9P
		REV: 1.0
		Date: 2020-03-03

Please use the battery in normal as follows, or it will be overheating, caught fire, reduced performance and shorten the life;

Environment condition

- (Temperature) Charging: 0~+45⁰C
 Discharging: -20~+50⁰C
 Store within 30 days: --20 ~ 50⁰C
 Store within 180 days: -20 ~ 45⁰C

If the kids use the battery, they should use as the operation instruction manual and guarantee that it must be use in normal at any time;

If the battery weeps, the electrolytes stick on the skin or cloth, use the water to wash or running water to wash
 To insure not install the battery wrong or wastage of the battery, please read the instruction carefully to install and dismounting;

If the battery will not be used for a long time, please take out of the battery from the device and store in dry and shady places;

If there is sludge on the surface of the battery, please wipe up clean before using, or it will lead bad contact with the device.

! Special Notice

Keep the cells in **50% charged state** during long period storage. We recommend to charge the battery up to 50% of the total capacity every 3 months after receipt of the battery and maintain the voltage 11.1~11.7V. And store the battery in cool and dry place.